

2638A-101

Current Shunt Resistors

Instruction Sheet

Introduction

The following installation instructions are for the 2638A -101 Current Shunt Resistors.

Overview

The 2638A-101 Current Shunt Resistors (the “Shunt Resistors”) are mounted inside the Universal Input Module using the same screw terminals that accept the user's input wiring. This option contains 10 resistors for measuring up to 10 current channels.

Purpose

The current shunts are 10 Ω , $\pm 0.08\%$ resistors that support current measurement up to 100 mA. The resistors are placed in series with the circuit to be measured. The voltage across the resistor is directly proportional to the current flowing through it. The data acquisition instrument processes the resultant voltage into an equivalent current for display and recording (see Figure 1.)

Compatibility

The Shunt Resistors are compatible with any Fluke Calibration data acquisition instrument that uses a Universal Input Module. Note that the Shunt Resistors are for use with STRANDED wire. It is difficult to assure reliable connections if solid wire is used.

Contact Fluke Calibration

To contact Fluke Calibration, call one of the following telephone numbers:

- Technical Support USA: 1-877-355-3225
- Calibration/Repair USA: 1-877-355-3225
- Canada: 1-800-36-FLUKE (1-800-363-5853)
- Europe: +31-40-2675-200
- Japan: +81-3-6714-3114
- Singapore: +65-6799-5566
- China: +86-400-810-3435
- Brazil: +55-11-3759-7600
- Anywhere in the world: +1-425-446-6110

To see product information and download the latest manual supplements, visit Fluke Calibration’s website at www.flukecal.com.

To register your product, visit <http://flukecal.com/register-product>

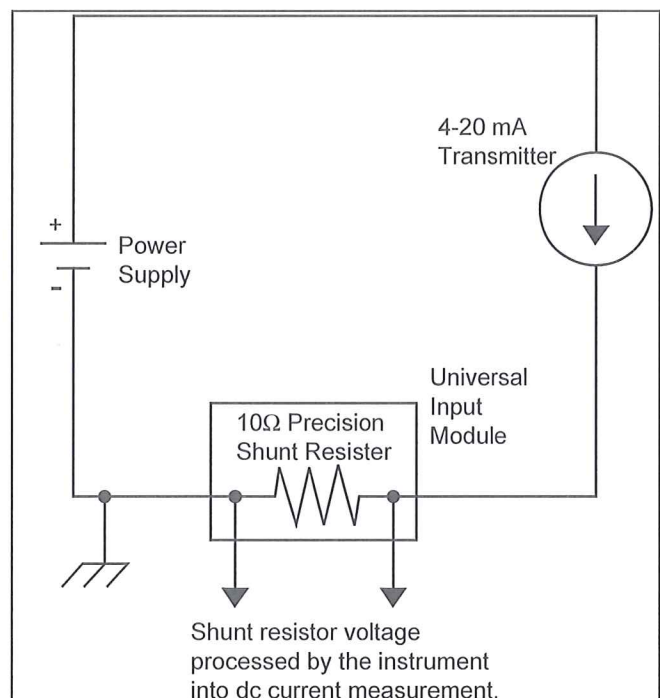

Figure 1. Current Shunt Resistor in a Two-Wire Transmitter Measurement Loop

Equipment Requirements

All necessary materials are supplied with the Shunt Resistors.

Description	Part No.	Quantity
Resistor, Shunt Set	103168	10
Installation Instruction Sheet	949651	1

Installation

Refer to Figures 2 and 3 for the following instructions.

1. Remove the Universal Input Module from the rear panel of the instrument by pushing the release tab on the sides of the module and pulling the module free.
2. Unlock the two cam locks on top and open the module.
3. Loosen the screws for the selected measurement channel(s) and place the Shunt Resistor(s) in position with the white side up (Figure 2). You can connect up to 10 measurement channels with each Shunt Resistor.
4. Connect the associated wires to H (high-positive) and L (low-negative) for each channel and tighten the securing screws.
5. Thread the wires through the strain-relief pins and out the back of the module.
6. Close the module cover, secure the locking cams and insert the module into the connector slot at the rear of the instrument until it latches into place (Figure 3).

Express Current Measurements in Engineering Units

The Fluke Calibration data acquisition instrument in use can also scale its readings into engineering units by means of its Mx + B scaling capability. The M and B coefficients are calculated as follows:

$$M = (\text{Display Hi} - \text{Display Lo}) / (\text{Input Hi} - \text{Input Lo})$$

$$B = \text{Display Lo} - (M * \text{Input Lo})$$

For example, if using a 0-1000 psi pressure transducer which outputs 4-20 mA. You could use the instrument's Mx+B scaling to perform the engineering units conversion as follows:

$$M = (1000 - 0) / (20 - 4) = 1000/16 = 62.5$$

$$B = 0 - (62.5 * 4) = 0 - 250 = -250$$

By enabling the Mx+B scaling for the channel and entering the values M = 62.5 and B = -250 you can cause your Fluke Data Acquisition Unit to display and record the readings in the desired engineering units, in this case psi.

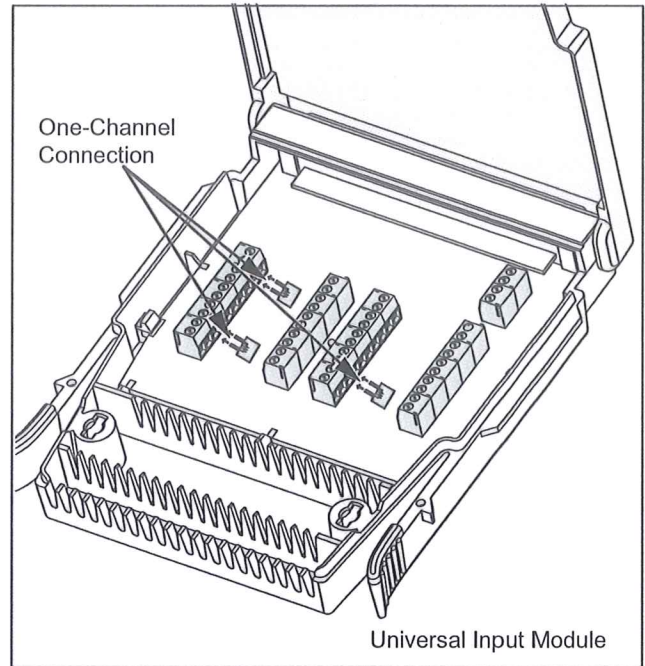

Figure 2. Position of the 2638A-101

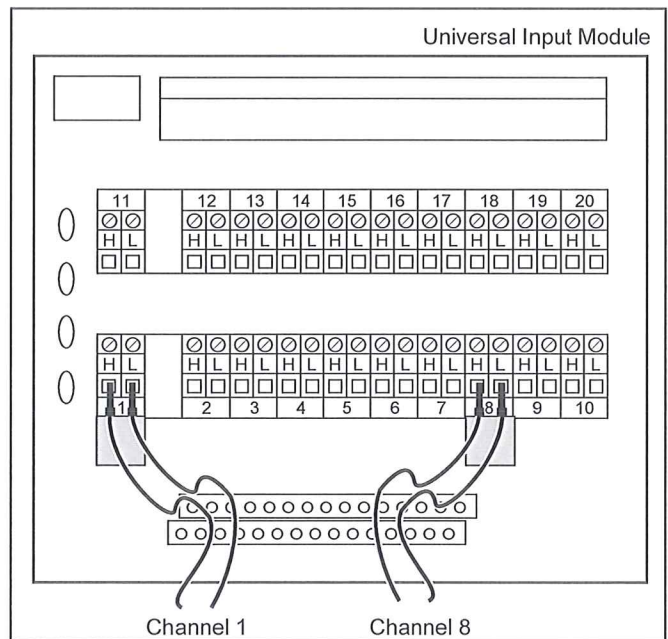

Figure 3. Completed 2638A-101 Installation (Typical)